

NetWay5ES

5-Port PoE+ Switch



Altronix NetWay5ES Hardened PoE+ Switch board allows for system expansion by accommodating up to four (4) IP cameras/devices over a single CAT5 or higher structured cable. Power up to 90W can be provided by Altronix NetWay1BT 802.3bt PoE injector, or any IEEE 802.3bt standard midspan/endspan typically located at the MDF (Main Distribution Frame).

For managed switch see model NetWay5ESQ.

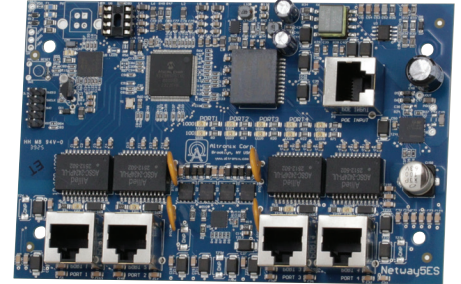

NetWay5ES

Key Features

- For remote installation and deploying up to 4-IP cameras/devices
- 30W maximum power per port (90W total combined)
- IEEE 802.3at (30W) compliant
- Data rate: 10/100/1000
- Port status LEDs
- Auto detection and protection of legacy non-PoE cameras/devices
- CE European Conformity
- Lifetime Warranty

Typical Application

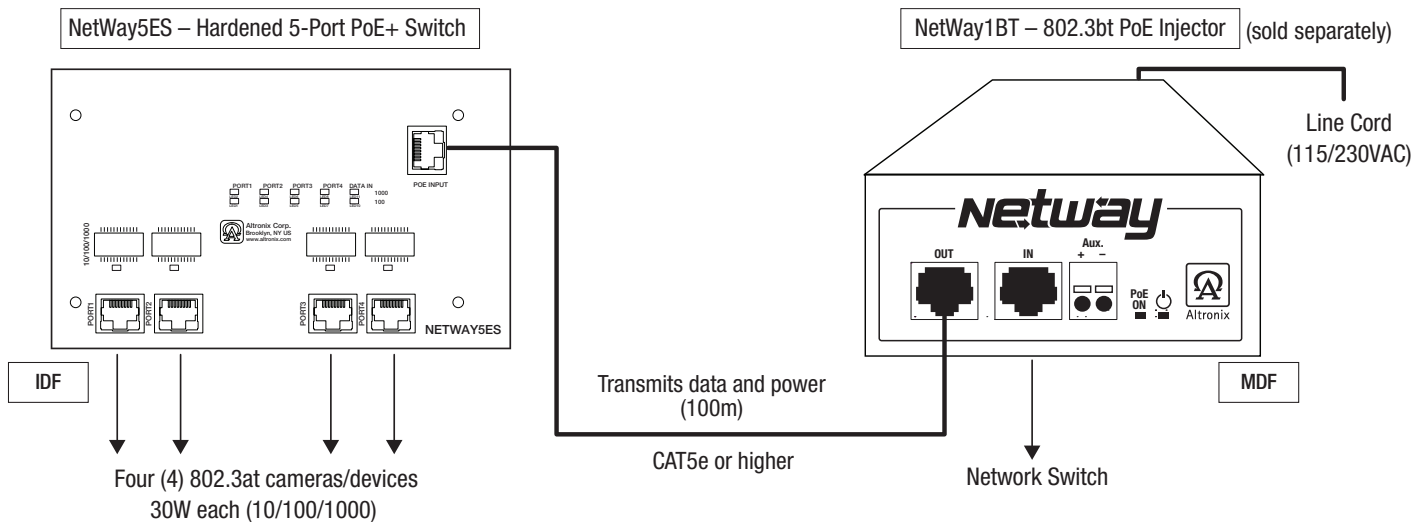

Lifetime Warranty

Specifications

Input

802.3bt PoE (90W)

Output

Maximum power per port:

PoE+ (30W each), 90W total combined

Power provided using all 4 pairs on structured cable

Ethernet

Connectivity: RJ45, auto-crossover

Wire type: 4-pair CAT5e or better structured cable

Distance: up to 100m

Speed: 10/100/1000 half/full duplex, auto negotiation

Indicators (LED)

Yellow and Green LED (by RJ45 jack):

IP Link status, 100/1000Base-T/active

Agency Listings

CE

European Conformity

Physical and Environmental

Dimensions (W x L x H)

Board: 5.9" x 3.6" x 0.75" (150mm x 91.4mm x 19mm)

Shipping: 8" x 6" x 5" (203.2mm x 152.4mm x 127mm)

Weight (total approx.)

Product Weight: 0.25 lb. (0.11 kg)

Shipping Weight: 0.75 lb. (0.34 kg)

Temperature

Operating: -40°C to 75°C (-40°F to 167°F)

Storage: -40°C to 75°C (-40°F to 167°F)

Relative Humidity 85% +/- 5%

Operating Altitude: -304.8 to 2,000m

Mounting hardware is included

Accessories (order separately)



NetWay1BT - 802.3bt PoE Injector

Single port midspan injector provides up to 90W (115/230VAC input via linecord)



BR1 - Sub-Assembly Mounting Bracket

Altronix BR1 mounting bracket is compatible with Altronix Maximal and Trove enclosures allowing sub-assembly modules to be mounted to the enclosure's inside wall, saving valuable space.



DNP1 - DIN Rail Mounting Plate

Altronix DNP1 DIN Rail Mounting Plate allows for easy installation of Altronix Power Supplies and sub-assemblies onto a standard 35mm DIN rail such as Altronix D10, D12, D19 or D24 - sold separately.



MM4 - Magnetic Mounting Solution

Altronix mounting magnets accommodate screws and nylon spacers to allow for mounting various boards/accessories in any metal enclosure or backplane.

Lifetime Warranty

Altronix Corporation | 140 58th St | Brooklyn, NY 11220 USA

phone: +1 718.567.8181 | fax: +1 718.567.9056 | email: info@altronix.com | www.altronix.com

Dimensions and Drawing

Board Dimensions (L x W x H approximate)

5.9" x 3.6" x 0.75" (150mm x 91.4mm x 19mm)

Mounting Holes' Tolerance: +/- 0.04 in. (1mm)

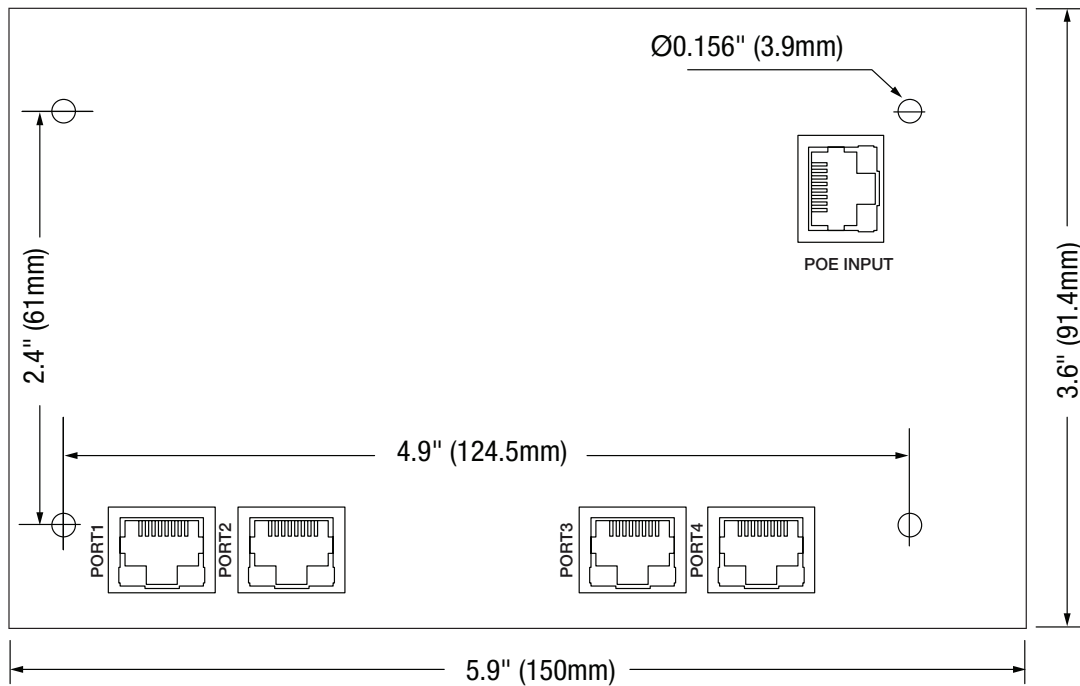

Lifetime Warranty

Altronix Corporation | 140 58th St | Brooklyn, NY 11220 USA

phone: +1 718.567.8181 | fax: +1 718.567.9056 | email: info@altronix.com | www.altronix.com