

Access & Power Integration

# Altronix/Mercury Wired Kits

## Models Include:

### T2M7XK1V

8 Door Kit with Fused Outputs

Accommodates one (1) Intelligent Dual Reader Controller and three (3) Dual Reader Interface Modules.

### T2M7XK2V

6 Door Kit with Fused Outputs

Accommodates one (1) Intelligent Controller and three (3) Dual Reader Interface Module.

### T2M7XK3V

8 Door Kit with Fused Outputs

Accommodates up to four (4) Dual Reader Interface Modules.

Each fully assembled kit includes:

- Trove2 enclosure with TM2 Altronix/Mercury backplane
- One (1) eFlow104NBV - Power Supply/Charger
- One (1) ACMS8 - Dual Input/Output Fuse Protected Access Power Controller
- One (1) VR6 - Voltage Regulator
- One (1) PDS8 - Dual Input/Output Fuse Protected Power Distribution Module
- One (1) Rocker Switch Bracket with One (1) Rocker Switch
- Wire harnesses and finger duct

### T2M7XK1DV

8 Door Kit with PTC Outputs

Accommodates one (1) Intelligent Dual Reader Controller and three (3) Dual Reader Interface Modules.

### T2M7XK2DV

6 Door Kit with PTC Outputs

Accommodates one (1) Intelligent Controller and three (3) Dual Reader Interface Module.

### T2M7XK3DV

8 Door Kit with PTC Outputs

Accommodates up to four (4) Dual Reader Interface Modules.

Each fully assembled kit includes:

- Trove2 enclosure with TM2 Altronix/Mercury backplane
- One (1) eFlow104NBV - Power Supply/Charger
- One (1) ACMS8CB - Dual Input/Output PTC Protected Access Power Controller
- One (1) VR6 - Voltage Regulator
- One (1) PDS8CB - Dual Input/Output PTC Protected Power Distribution Module
- One (1) Rocker Switch Bracket with One (1) Rocker Switch
- Wire harnesses and finger duct

Please refer to the included corresponding Sub-Assembly Installation Guides for further information.

# Installation Guide



All registered trademarks are property of their respective owners.

Rev. T2M7XKV\_070623

Installing Company: \_\_\_\_\_ Service Rep. Name: \_\_\_\_\_

Address: \_\_\_\_\_ Phone #: \_\_\_\_\_



More than just power.™

## Overview:

Altronix Trove Plus kits are pre-wired, pre-assembled and consist of Trove2M2 enclosure/backplane with factory installed Altronix power supply/charger and sub-assemblies, wire harnesses and finger duct.

## Configuration Chart:

Altronix Model Number	220VAC 50/60Hz Input Current (A)	Power Supply Board Input Fuse Rating	Power Supply Board Battery Fuse Rating	Nominal DC Output Voltage		Maximum Supply Current for Main and Aux. Outputs on Power Supply board and ACMS8(CB) Access Power Controller's outputs	Fail-Safe/Fail-Secure or Dry Form "C" Outputs	Current Per ACMS8(CB) and PDS8(CB) Output (A)	ACMS8(CB) Board Input Fuse (PTC) Rating	ACMS8(CB) Board Output Fuse (PTC) Rating	PDS8(CB) Board Input Fuse (PTC) Rating	PDS8(CB) Board Output Fuse (PTC) Rating
				[DC]	[Aux]							
				Output Range (VDC)	Output Range (VDC)							
T2M7XK1V	2.7	6.3A/250V	15A/32V	20.17-26.4	20.28-26.4	24VDC @ 9.4A	8	2.5	15A/250V	3A/250V	10A/250V	3A/250V
T2M7XK2V												
T2M7XK3V												
T2M7XK1DV												
T2M7XK2DV												
T2M7XK3DV												

## Hardware and Accessories:

- One(1) tamper switch (Altronix Model TS112 or equivalent).
- Cam lock.
- Battery leads.

## Mechanical:

- 16 Gauge enclosure with ample knockouts for convenient access.
- Enclosure Dimensions (H x W x D): 27.25" x 21.75" x 6.5" (692.2mm x 552.5mm x 165.1mm).

## Installation Instructions:

Wiring methods shall be in accordance with the National Electrical Code/NFPA 70/ANSI, and with all local codes and authorities having jurisdiction. Product is intended for indoor use only.

1. Remove backplane from enclosure. Do not discard hardware.
2. Mark and predrill holes in the wall to line up with the top three keyholes in the enclosure. Install three upper fasteners and screws in the wall with the screw heads protruding. Place the enclosure's upper keyholes over the three upper screws, level and secure. Mark the position of the lower three holes. Remove the enclosure. Drill the lower holes and install the three fasteners. Place the enclosure's upper keyholes over the three upper screws. Install the three lower screws and make sure to tighten all screws.
3. Mount included UL Listed tamper switch (Altronix Model TS112 or equivalent) in desired location, opposite hinge. Slide the tamper switch bracket onto the edge of the enclosure approximately 2" from the right side (*Fig. 1, pg. 2*). Connect tamper switch wiring to the Access Control Panel input or the appropriate UL Listed reporting device. To activate alarm signal open the door of the enclosure.
4. Refer to the *eFlow Power Supply/Charger Installation Guide* for eFlow104NBV and corresponding *Sub-Assembly Installation Guides* for PDS8(CB) and ACMS8(CB) for further installation instructions.
5. Position Mercury access controller modules over corresponding spacers and depress onto snap on spacers (*Fig. 2-4, pg. 3-5*).
6. Connect wire harnesses to Mercury access controller modules (*Fig. 2-4, pg. 3-5*).
7. Mount backplane to enclosure with hardware.

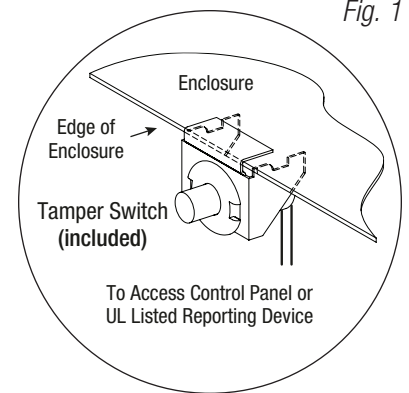

## T2M7XK1(D)V Configuration:

1. Position access controller module over corresponding spacers and depress onto snap on spacers (Fig. 2, pg. 3).
2. Mount backplane to enclosure with hardware.

### Access Controller Position Chart for the Following Models:

LenelS2 / Mercury Access Controller	Pem Mounting
LNL-2220 / LP1502	(A)
LNL-1320 / MR52	(B)

Fig. 2

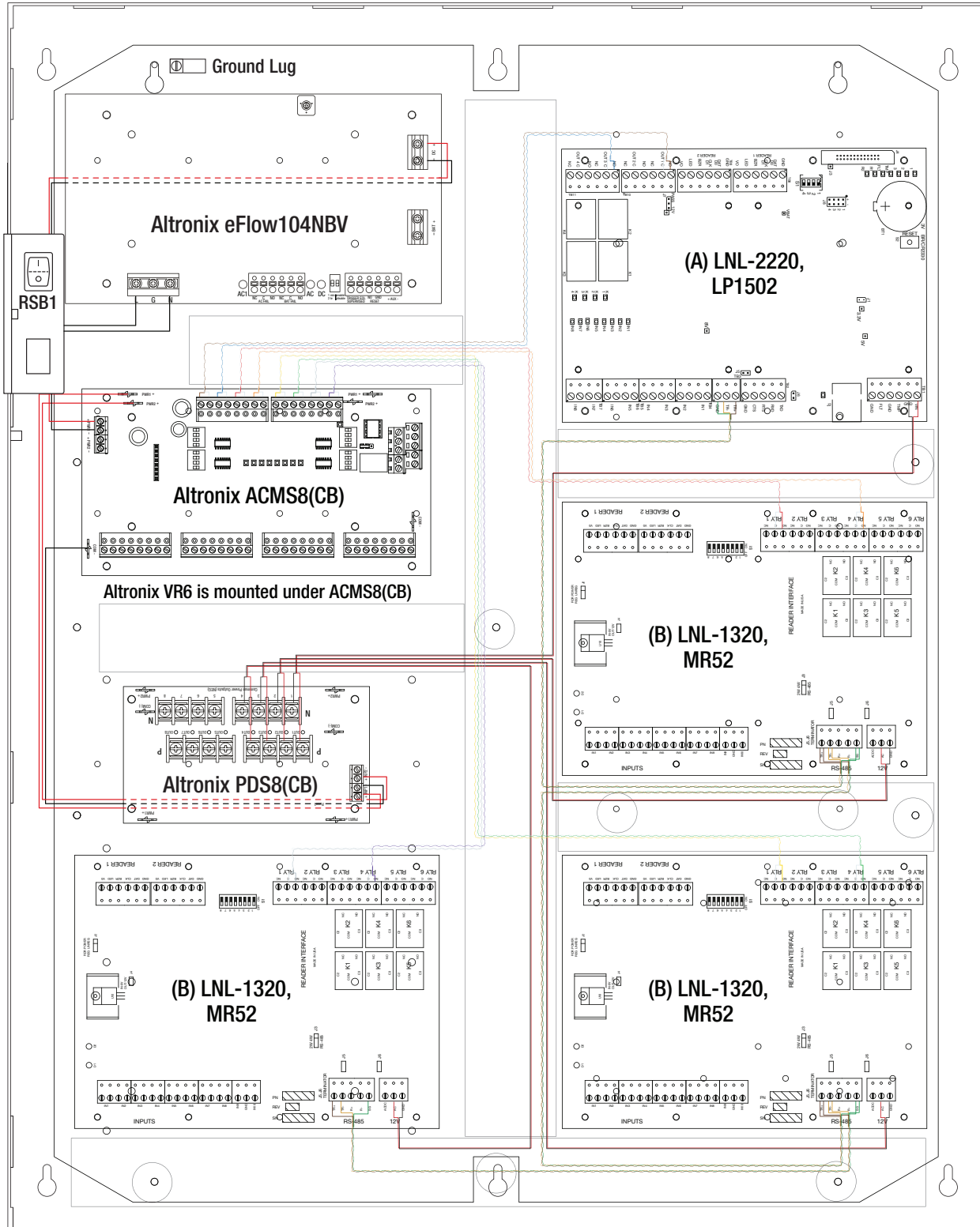

## T2M7XK2(D) Configuration:

1. Position access controller module over corresponding spacers and depress onto snap on spacers (Fig. 3, pg. 4).
2. Mount backplane to enclosure with hardware.

### Access Controller Position Chart for the Following Models:

LenelS2 / Mercury Access Controller	Pem Mounting
LNL-3300 / LP2500	(A)
LNL-1320 / MR52	(B) (C) (D)

Fig. 3

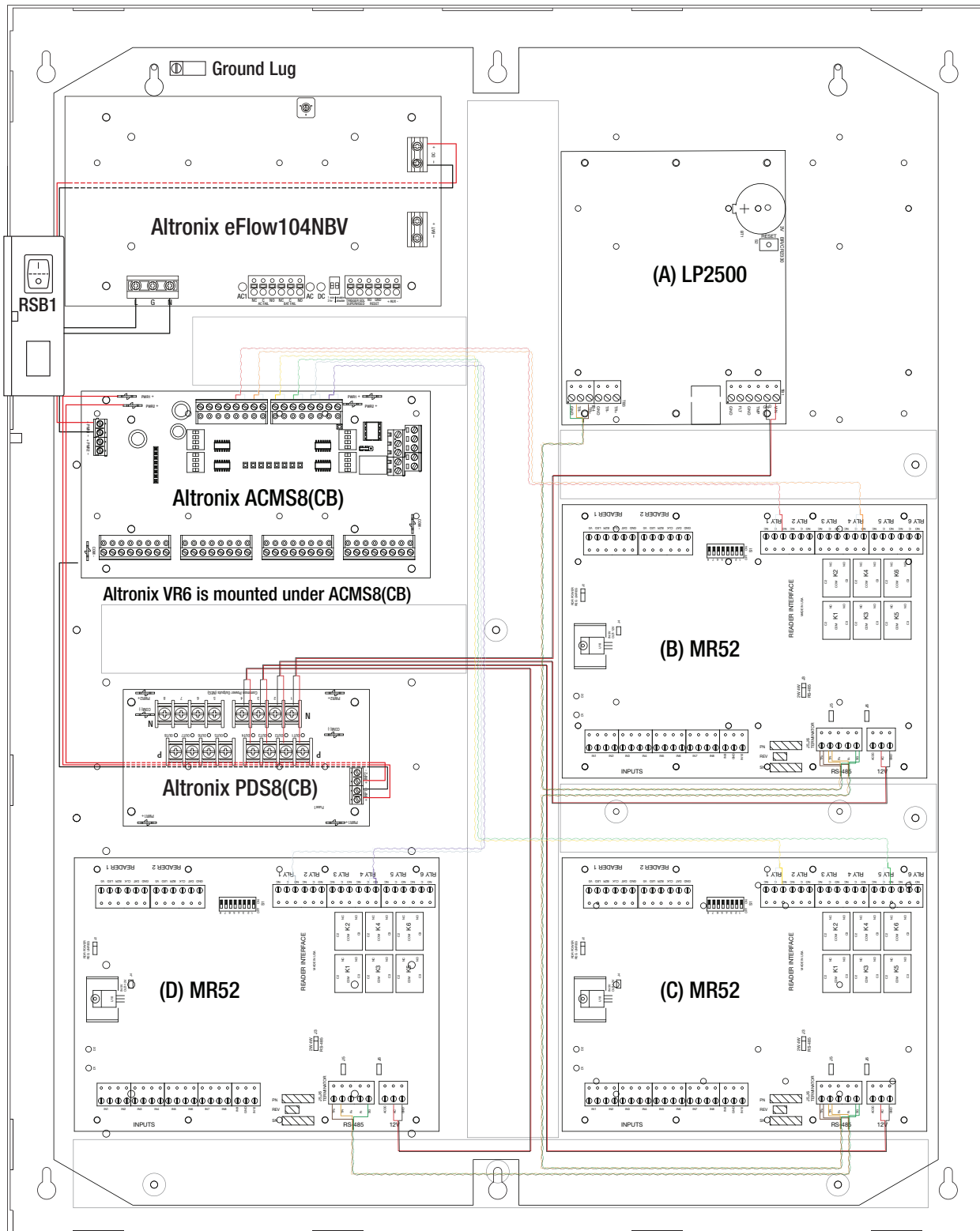

## T2M7XK3(D) Configuration:

1. Position access controller module over corresponding spacers and depress onto snap on spacers (Fig. 4, pg. 5).
2. Mount backplane to enclosure with hardware.

### Access Controller Position Chart for the Following Models:

LenelS2 / Mercury Access Controller	Pem Mounting
LNL-1320 / MR52	(A) (B) (C) (D)

Fig. 4

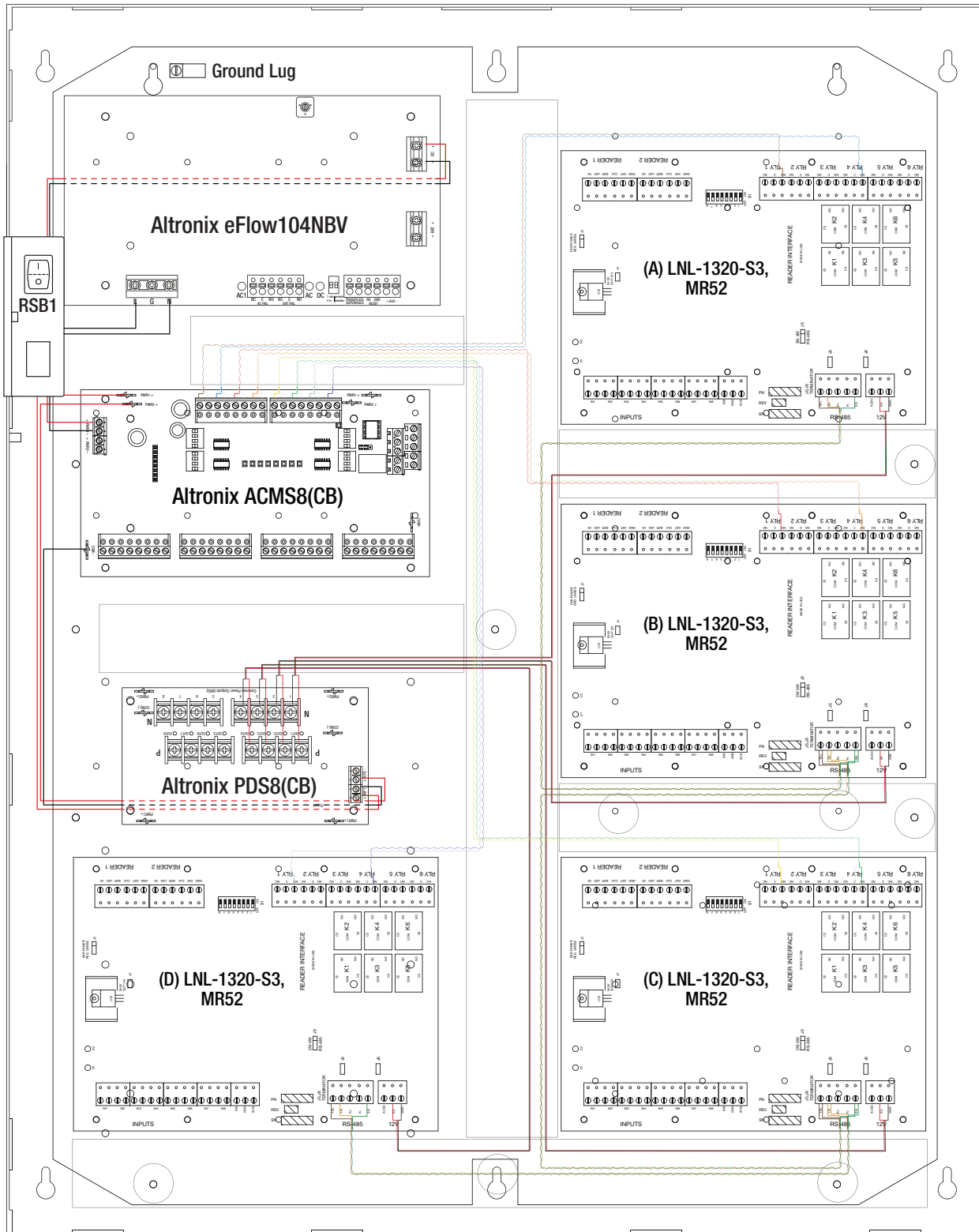



## eFlow Power Supply/Chargers can be Controlled and Monitored while Reporting Power/Diagnostics from Anywhere over the Network...

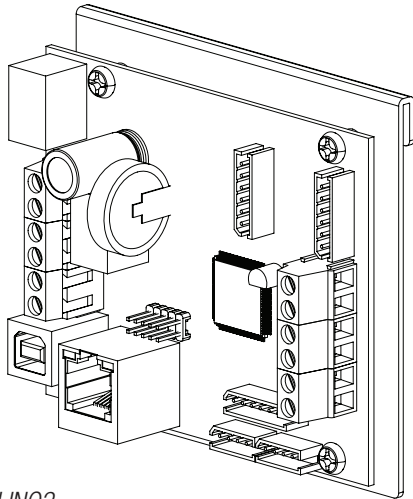

# LINQ™

### LINQ2 - Network Communication Module

LINQ2 provides remote IP access to real-time data from eFlow power supply/chargers to help keep systems up and running at optimal levels. It facilitates fast and easy installation and set-up, minimizes system downtime, and eliminates unnecessary service calls, which helps reduce Total Cost of Ownership (TCO) - as well as creating a new source of Recurring Monthly Revenue (RMR).

LINQ2

### Features:

- UL Listed in the U.S. and Canada.
- Local or remote control of up to (2) two Altronix eFlow power output(s) via LAN and/or WAN.
- Monitor real time diagnostics: DC output voltage, output current, AC & battery status/service, input trigger state change, output state change and unit temperature.
- Access control and user management: Restrict read/write, Restrict users to specific resources
- Two (2) integral network controlled Form "C" Relays.
- Three (3) programmable input triggers: Control relays and power supplies via external hardware sources.
- Email and Windows Dashboard notifications
- Event log tracks history.
- Secure Socket Layer (SSL).
- Programmable via USB or web browser - includes operating software and 6 ft. USB cable.

### LINQ2 Mounts Inside any Trove Enclosure

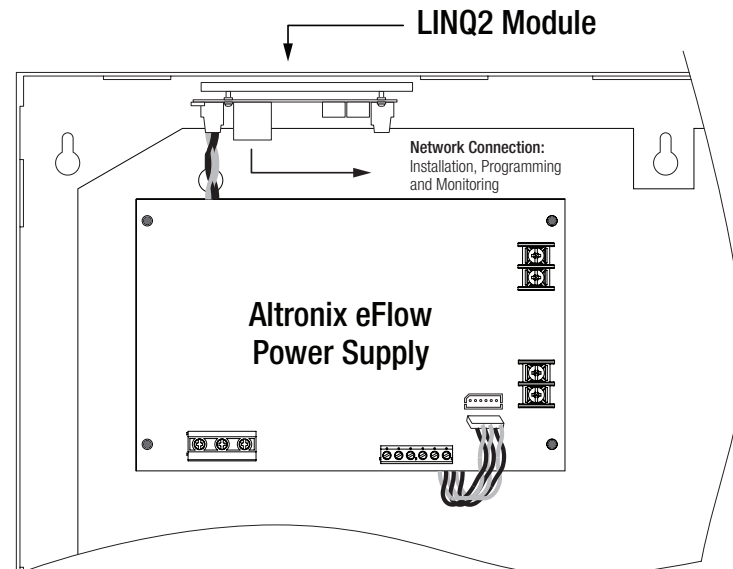

## Notes:

## Trove2 Enclosure Dimensions (H x W x D approximate):

27.25" x 21.5" x 6.5" (692.2mm x 552.5mm x 165.1mm)

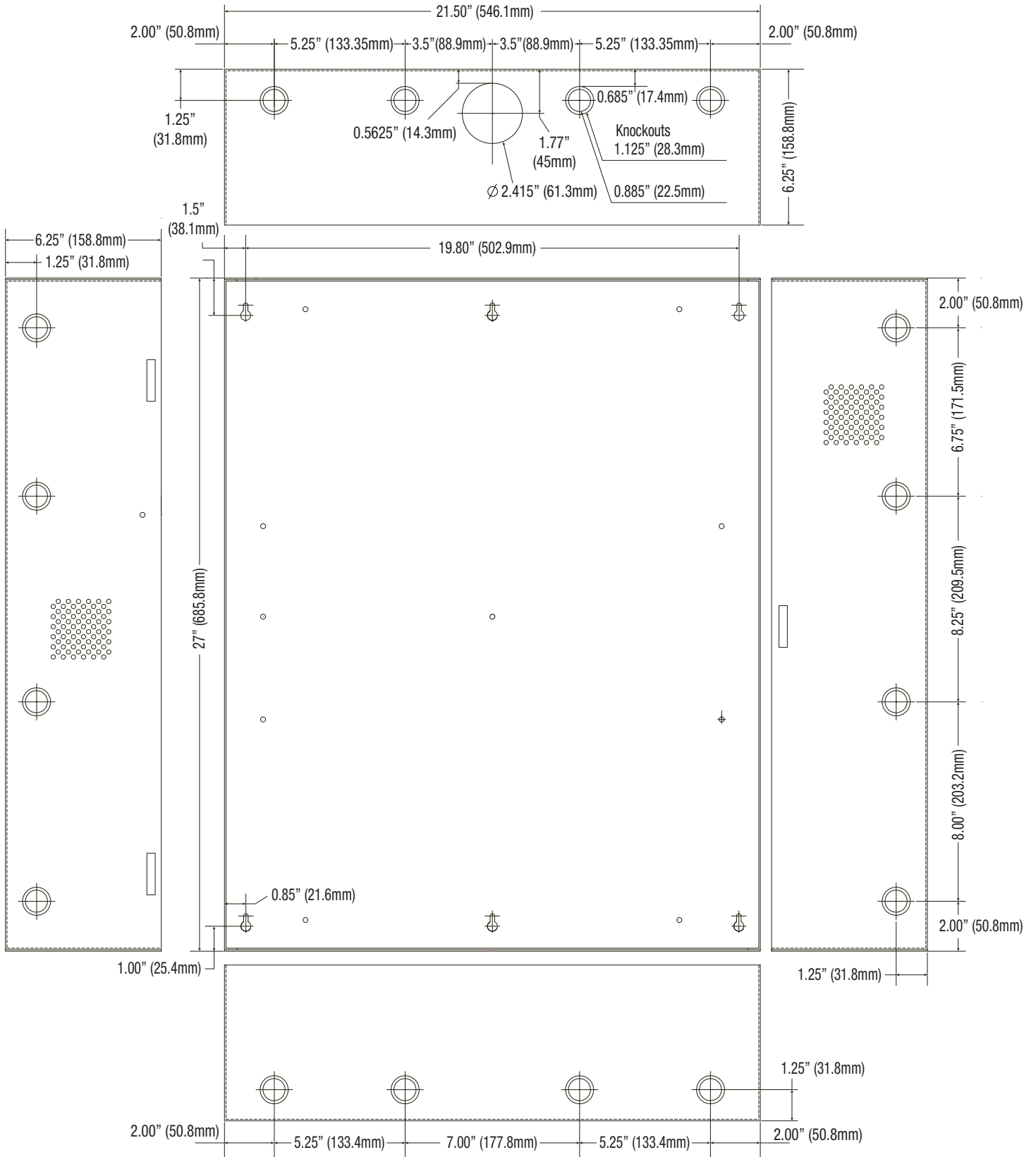

Altronix is not responsible for any typographical errors. Product specifications are subject to change without notice.

140 58th Street, Brooklyn, New York 11220 USA | phone: 718-567-8181 | fax: 718-567-9056  
 website: [www.altronix.com](http://www.altronix.com) | e-mail: [info@altronix.com](mailto:info@altronix.com) | Lifetime Warranty  
 IIT2M7XKV Kit Series

G06W

