

TRIVE™

Access & Power Integration

Altronix/Software House Kits

Models Include:

T3SK777F24S

24 Door Kit with Fused Outputs

Fully assembled kit includes:

- Trove3 enclosure with TSH3 Altronix/Software House backplane
- Three (3) eFlow104NB - Power Supply/Chargers
- Two (2) ACMS12 - Fuse Protected Access Power Controllers
- Two (2) PDS16 - Fuse Protected Power Distribution Modules
- Two (2) VR6 - Voltage Regulators
- Two (2) Rocker Switch Brackets with Three (3) Rocker Switches

T3SK777F24SD

24 Door Kit with PTC Outputs

Fully assembled kit includes:

- Trove3 enclosure with TSH3 Altronix/Software House backplane
- Three (3) eFlow104NB - Power Supply/Chargers
- Two (2) ACMS12CB - PTC Protected Access Power Controllers
- Two (2) PDS16CB - PTC Protected Power Distribution Modules
- Two (2) VR6 - Voltage Regulators
- Two (2) Rocker Switch Brackets with Three (3) Rocker Switches

Please refer to the included corresponding Sub-Assembly Installation Guides for further information.

Installation Guide



All registered trademarks are property of their respective owners.

Rev. 042624

Installing Company: _____ Service Rep. Name: _____

Address: _____ Phone #: _____



More than just power.™

Overview:

Altronix Trove Software House kits are pre-assembled and consist of Trove enclosure with factory installed Altronix power supply/chargers and sub-assemblies. These kits also accommodate various combinations of Software House boards for up to twenty four (24) doors in a single enclosure.

Configuration Chart:

Altronix Model Number	120VAC 60Hz Input Current (A)	Power Supply Board Input Fuse Rating	Power Supply Board Battery Fuse Rating	Nominal DC Output Voltage Range						Maximum Supply Current for Main Output on Power Supply board and ACMS12(CB) Access Power Controller's outputs (A)	Fail-Safe/ Fail-Secure Outputs	Current Per ACMS12(CB) Output (A)	ACMS12(CB) and PDS16(CB) Boards Input Fuse (PTC) Rating	ACMS12(CB) and PDS16(CB) Boards Output Fuse (PTC) Rating
				Power Supply 1		Power Supply 2		Power Supply 3						
				[DC]	[Aux]	[DC]	[Aux]	[DC]	[Aux]					
				Output Range (VDC)	Output Range (VDC)	Output Range (VDC)	Output Range (VDC)	Output Range (VDC)	Output Range (VDC)					
T3SK777F24S	13.5	6.3A/ 250V	15A/ 32V	20.17- 26.4	20.28- 26.4	20.17- 26.4	20.28- 26.4	20.17- 26.4	20.28- 26.4	24VDC @ 9.2A	24	2.5	15A/ 32V	3A/ 32V
T3SK777F24SD	13.5	6.3A/ 250V	15A/ 32V	20.17- 26.4	20.28- 26.4	20.17- 26.4	20.28- 26.4	20.17- 26.4	20.28- 26.4	24VDC @ 9.2A	24	2.5	9A	2.5A

Hardware and Accessories:

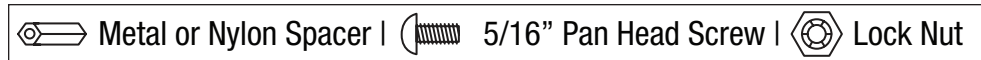

- Two (2) tamper switches (Altronix Model TS112 or equivalent).
- Cam lock.
- Battery leads.

Installation Instructions:

Wiring methods shall be in accordance with the National Electrical Code/NFPA 70/ANSI, and with all local codes and authorities having jurisdiction. Product is intended for indoor use only.

1. Remove backplane from enclosure. Do not discard hardware.
2. Mark and predrill holes in the wall to line up with the top three keyholes in the enclosure. Install three upper fasteners and screws in the wall with the screw heads protruding. Place the enclosure's upper keyholes over the three upper screws, level and secure. Mark the position of the lower three holes. Remove the enclosure. Drill the lower holes and install the three fasteners. Place the enclosure's upper keyholes over the three upper screws. Install the three lower screws and make sure to tighten all screws.
3. Mount included UL Listed tamper switch (Altronix Model TS112 or equivalent) in desired location, opposite hinge. Slide the tamper switch bracket onto the edge of the enclosure approximately 2" from the right side (*Fig. 1, pg. 2*). Connect tamper switch wiring to the Access Control Panel input or the appropriate UL Listed reporting device. To activate alarm signal open the door of the enclosure.
4. Mount Software House boards to backplane, *refer to page 3*.
5. Refer to the eFlow Power Supply/Charger Installation Guide for eFlow104NB and corresponding *Sub-Assembly Installation Guides* for the following models: ACMS12(CB), PDS16(CB) and VR6 for further installation instructions.

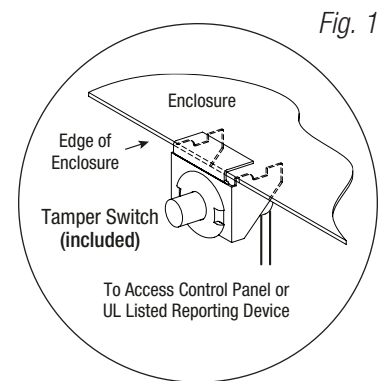
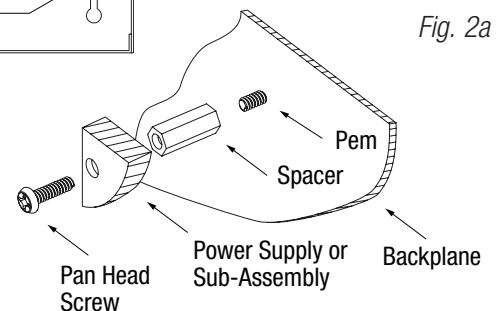
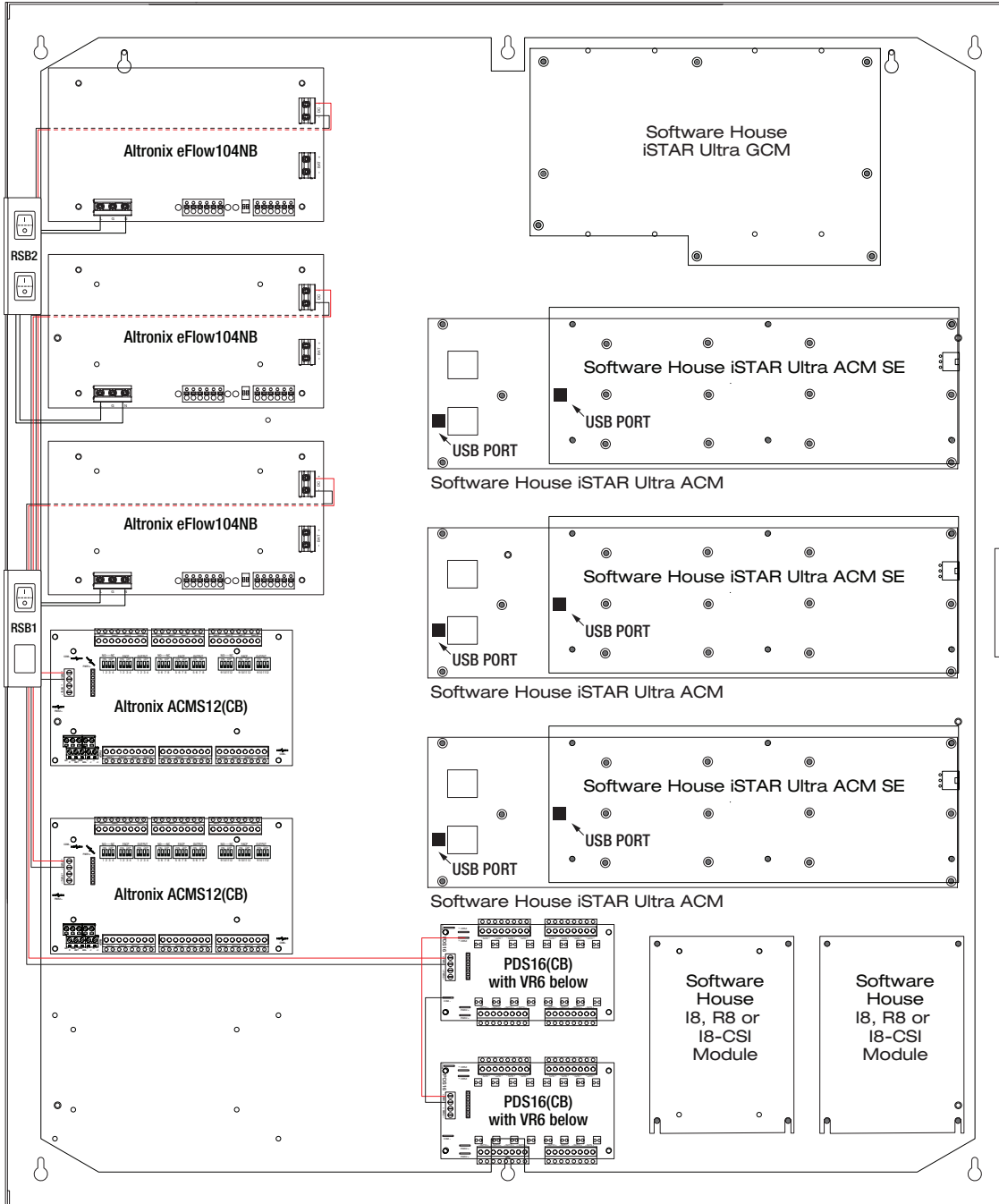

Fig. 1

T3SK777F24S(D): Configuration of Software House iSTAR Ultra ACM Boards

1. Align the Software House boards on the backplane to match the boards' mounting holes with pems provided.
2. Fasten spacers (provided) to pems that match the hole pattern for Software House iSTAR Ultra GCM, iSTAR Ultra ACM, and/or I8, R8, I8-CSI boards (Fig. 2, 2a, pg. 3).
3. Mount Software House boards to spacers utilizing provided 5/16" pan head screws (Fig. 2a, pg. 3).
Note: Software House iSTAR Ultra ACM boards have one (1) USB port each.
 Please orient the board in the appropriate position according to the Fig. 2 below.
4. Fasten backplane to Trove3 enclosure utilizing lock nuts (provided).

Fig. 2



Enclosure Dimensions (H x W x D approximate):
 36.12" x 30.125" x 7.06" (917.5mm x 768.1mm x 179.3mm)

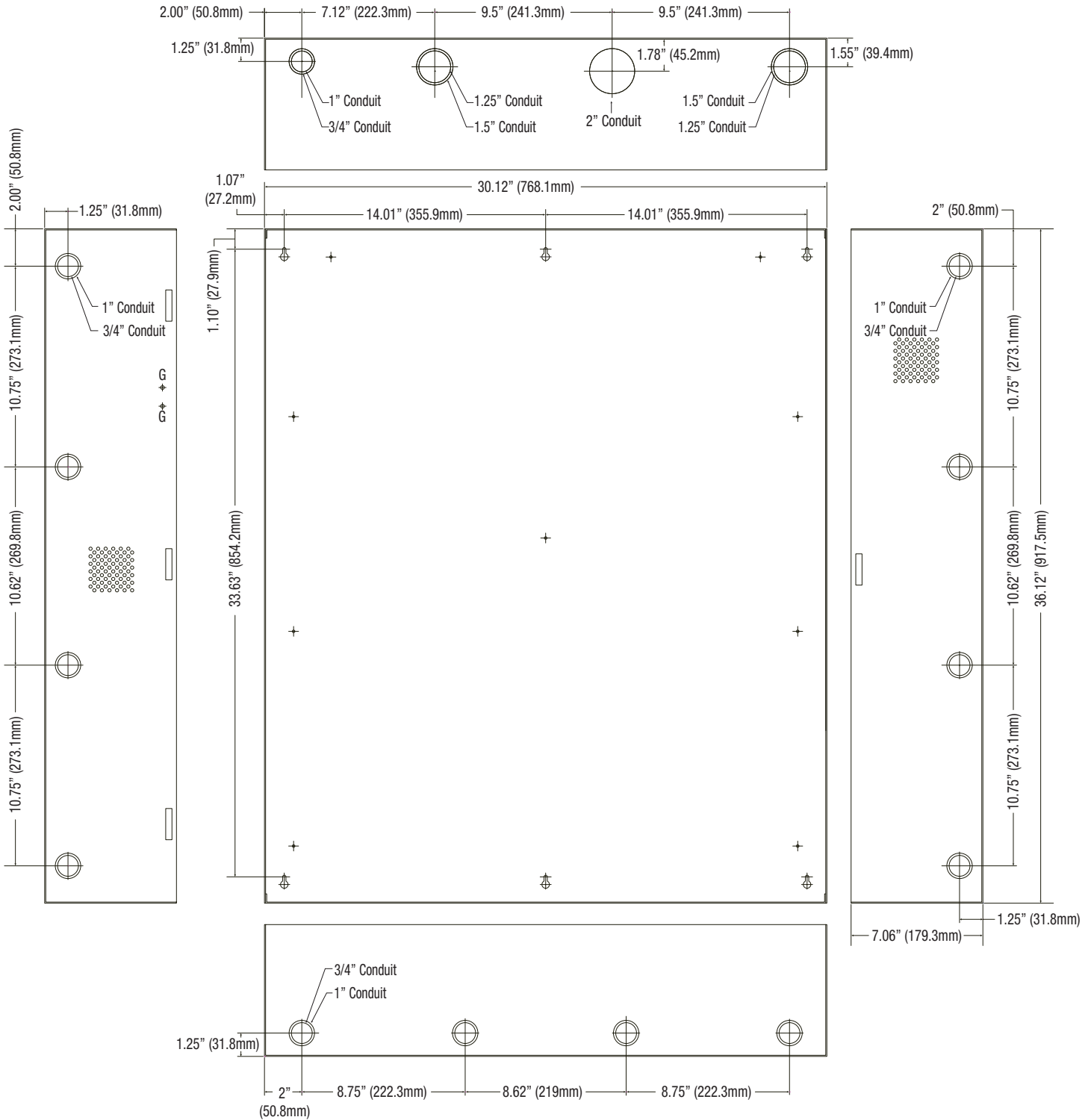

Altronix is not responsible for any typographical errors.

140 58th Street, Brooklyn, New York 11220 USA | phone: 718-567-8181 | fax: 718-567-9056
 web site: www.altronix.com | e-mail: info@altronix.com | Lifetime Warranty
 IIT3SK777F24S(D)

D26X

