

# TROVE™

## Altronix/CDVI Kits

### Models Include:

#### T1CVK3F4

4 Door Kit with Fused Outputs

Fully assembled kit includes:

- Trove1 enclosure with TC1 Altronix/CDVI backplane
- One (1) eFlow6NB - Power Supply/Charger
- One (1) ACM4 - Fused Access Power Controller

#### T2CVK7F10

10 Door Kit with Fused Outputs

Fully assembled kit includes:

- Trove2 enclosure with TCV2 Altronix/CDVI backplane
- One (1) eFlow104NB - Power Supply/Charger
- One (1) ACM8 - Fused Access Control Module
- One (1) ACM4 - Fused Access Control Module
- One (1) PD8UL - Fused Power Distribution Module

#### T2CVK33F10

10 Door Kit with PTC Outputs

Fully assembled kit includes:

- Trove2 enclosure with TCV2 Altronix/CDVI backplane
- Two (2) eFlow6NB - Power Supply/Chargers
- Two (2) MOM5 - PTC Power Distribution Modules with Fire Alarm Interface

#### T3CVK77F20

20 Door Kit with Fused Outputs

Fully assembled kit includes:

- Trove3 enclosure with TCV3 Altronix/CDVI backplane
- Two (2) eFlow104NB - Power Supply/Chargers
- Two (2) ACM8 - Fused Access Control Modules
- One (1) ACM4 - Fused Access Control Module
- One (1) PD8UL - Fused Power Distribution Module
- One (1) RSB2 - Rocker Switch Bracket with Two (2) Rocker Switches (Not evaluated by UL)

#### T1CVK3F4D

4 Door Kit with PTC Outputs

Fully assembled kit includes:

- Trove1 enclosure with TC1 Altronix/CDVI backplane
- One (1) eFlow6NB - Power Supply/Charger
- One (1) ACM4CB - PTC Access Power Controller

#### T2CVK7F10D

10 Door Kit with PTC Outputs

Fully assembled kit includes:

- Trove2 enclosure with TCV2 Altronix/CDVI backplane
- One (1) eFlow104NB - Power Supply/Charger
- One (1) ACM8CB - PTC Access Control Module
- One (1) ACM4CB - PTC Access Control Module
- One (1) PD8ULCB - PTC Power Distribution Module

#### T2CVK33F10Q

10 Door Networked Kit with PTC Outputs

Fully assembled kit includes:

- Trove2 enclosure with TCV2 Altronix/CDVI backplane
- Two (2) eFlow6NB - Power Supply/Chargers
- One (1) LINQ2 - Network Communication Module
- Two (2) MOM5 - PTC Power Distribution Modules with Fire Alarm Interface

#### T3CVK77F20D

20 Door Kit with PTC Outputs

Fully assembled kit includes:

- Trove3 enclosure with TCV3 Altronix/CDVI backplane
- Two (2) eFlow104NB - Power Supply/Chargers
- Two (2) ACM8CB - PTC Access Control Modules
- One (1) ACM4CB - PTC Access Control Module
- One (1) PD8ULCB - PTC Power Distribution Module
- One (1) RSB2 - Rocker Switch Bracket with Two (2) Rocker Switches (Not evaluated by UL)

All components of these Trove kits are UL Listed sub-assemblies.

Please refer to the included corresponding Sub-Assembly Installation Guides for further information.

## Installation Guide

All registered trademarks are property of their respective owners.

Rev. TCVK\_112723

Installing Company: \_\_\_\_\_ Service Rep. Name: \_\_\_\_\_

Address: \_\_\_\_\_ Phone #: \_\_\_\_\_



More than just power.™

## Overview:

Altronix Trove CDVI kits are pre-assembled and consist of Trove enclosures/backplanes with factory installed Altronix power supply/chargers and sub-assemblies. These kits also accommodate various combinations of CDVI Atrium A22K/A22NB/ADH10 boards for up to twenty (20) doors in a single enclosure.

## Configuration Chart:

Altronix Model Number	120VAC 60Hz Input Current (A)	Power Supply Board Input Fuse Rating	Power Supply Board Battery Fuse Rating	Maximum Supply Current for Main and Aux. Outputs on Power Supply board, MOM5 power distribution module or ACM4(CB)/ACM8(CB) Access Power Controllers' outputs	Nominal DC Output Voltage		Fail-Safe/Fail-Secure or Dry Form "C" Outputs	Additional Fuse or PTC Protected Outputs	ACM4/ACM8 Board Input Fuse (PTC) Rating	ACM4(CB) Board Output Fuse (PTC) Rating	ACM8(CB) Board Input Fuse Rating	ACM8(CB) Board Output Fuse (PTC) Rating	PD8UL Board Output Fuse (PTC) Rating	MOM5 Output PTC Rating
					Power Supply									
					[DC]	[Aux]								
					Output Range (VDC)	Output Range (VDC)								
T1CVK3F4	3.5	5A/250V	10A/32V	24VDC @ 5.7A	20.17-26.4	20.28-26.4	4	-	10A/250V	3A/32V	-	-	-	-
T1CVK3F4D	3.5	5A/250V	10A/32V	24VDC @ 5.7A	20.17-26.4	20.28-26.4	4	-	9A	2.5A	-	-	-	-
T2CVK7F10	4.5	6.3A/250V	15A/32V	24VDC @ 9.4A	20.17-26.4	20.28-26.4	12	8	10A/250V	3.5A/250V	10A/250V	3.5A/250V	3.5A/250V	-
T2CVK7F10D	4.5	6.3A/250V	15A/32V	24VDC @ 9.4A	20.17-26.4	20.28-26.4	12	8	10A/250V	2.5A	10A/250V	2.5A	2.5A	-
T2CVK33F10	7.0	5A/250V	10A/32V	24VDC @ 5.9A + 24VDC @ 5.9A	20.17-26.4	20.28-26.4	-	10	-	-	-	-	-	2.5A
T2CVK33F10Q <i>Networked Kit</i>	7.0	5A/250V	10A/32V	24VDC @ 5.9A + 24VDC @ 5.9A	20.17-26.4	20.28-26.4	-	10	-	-	-	-	-	2.5A
T3CVK77F20	9.0	6.3A/250V	15A/32V	24VDC @ 9.4A + 24VDC @ 9.7A	20.17-26.4	20.28-26.4	20	8	10A/250V	3A/32V	10A/250V	3.5A/250V	3.5A/250V	-
					20.17-26.4	20.28-26.4								
T3CVK77F20D	9.0	6.3A/250V	15A/32V	24VDC @ 9.4A + 24VDC @ 9.7A	20.17-26.4	20.28-26.4	20	8	9A	2.5A	10A/250V	2.5A	3.5A/250V	-
					20.17-26.4	20.28-26.4								

## Installation Instructions:

Wiring methods shall be in accordance with the National Electrical Code/NFPA 70/ANSI, and with all local codes and authorities having jurisdiction. Product is intended for indoor use only.

- Remove backplane from enclosure. Do not discard hardware.  
**If your application requires a raised backplane, re-mount it using metal spacers and screws (provided).**
- Mark and predrill holes in the wall to line up with the top three keyholes in the enclosure. Install two/three upper fasteners and screws in the wall with the screw heads protruding. Place the enclosure's upper keyholes over the two/three upper screws; level and secure. Mark the position of the lower two/three holes. Remove the enclosure. Drill the lower holes and install the fasteners. Place the enclosure's upper keyholes over the upper screws. Install the lower screws and make sure to tighten all screws.
- Mount included UL Listed tamper switch(es) (Altronix Model TS112 or equivalent) in desired location, opposite hinge. Slide the tamper switch bracket onto the edge of the enclosure approximately 2" from the right side (*Fig. 1, pg. 2*). Connect tamper switch wiring to the Access Control Panel input or the appropriate UL Listed reporting device. To activate alarm signal open the door of the enclosure.
- Mount CDVI A22K/A22NB/ADH10 boards to backplane, *refer to pages 3-6*.
- Refer to the *eFlow Power Supply/Charger Installation Guide* (eFlow6NB, eFlow104NB) and corresponding *Sub-Assembly Installation Guide* (LINQ2, ACM4(CB), ACM8(CB), PD8UL(CB), MOM5) for further installation instructions.

Fig. 1

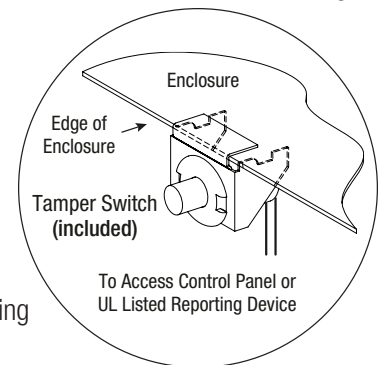

## T1CVK3F4(D): Configuration of CDVI A22K/A22NB/ADH10 Boards

1. Fasten spacers (supplied with A22K/A22NB/ADH10) to CDVI A22K/A22NB/ADH10 board (Fig. 2b, pg. 3).
2. Mount CDVI A22K/A22NB/ADH10 boards into the correct positions (Fig. 2, pg. 3) by positioning spacers over appropriate holes on the backplane and depressing down on board to secure spacer to the backplane (Fig. 2a, 2b, pg. 3).

**Note:** CDVI A22K/A22NB/ADH10 boards have one (1) RJ45 jack each.

Please make sure that they are mounted correctly, as shown in Fig. 2 below.

3. Fasten backplane to Trove2 enclosure utilizing pan head screws (provided).

Fig. 2

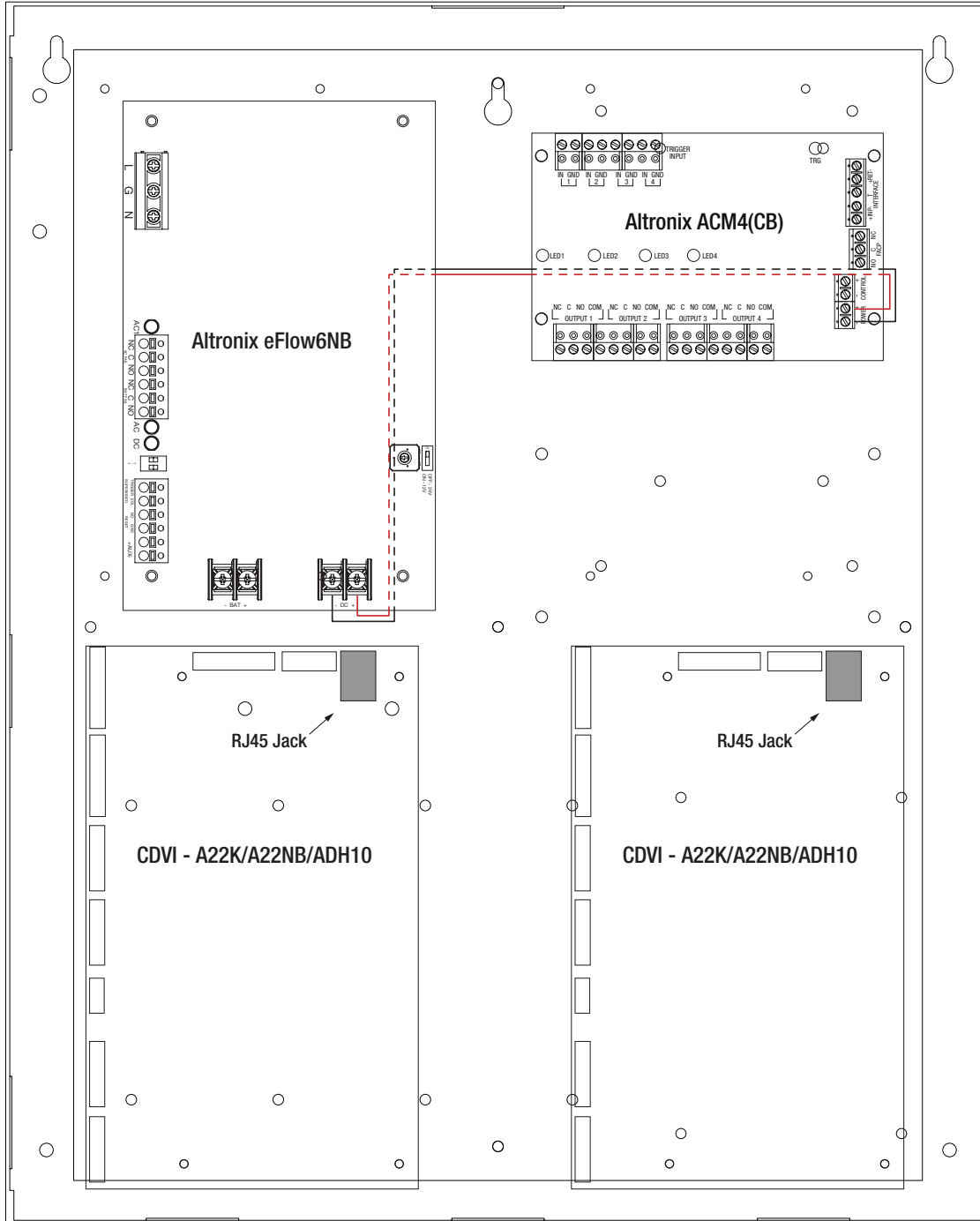

Fig. 2a

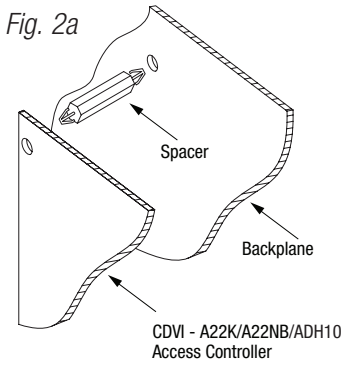
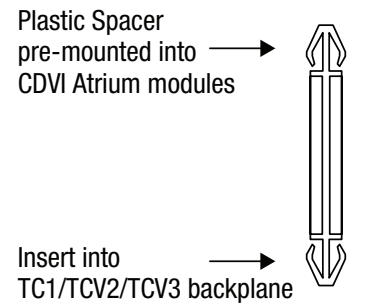

Fig. 2b



## T2CVK7F10(D): Configuration of CDVI A22K/A22NB/ADH10 Boards

1. Fasten spacers (supplied with A22K/A22NB/ADH10) to CDVI A22K/A22NB/ADH10 board (Fig. 3b, pg. 4).
2. Mount CDVI A22K/A22NB/ADH10 boards into the correct positions (Fig. 3, pg. 4) by positioning spacers over appropriate holes on the backplane and depressing down on board to secure spacer to the backplane (Fig. 3a, 3b, pg. 4).

**Note:** CDVI A22K/A22NB/ADH10 boards have one (1) RJ45 jack each.

Please make sure that they are mounted correctly, as shown in Fig. 3 below.

3. Fasten backplane to Trove2 enclosure utilizing pan head screws (provided).

Fig. 3

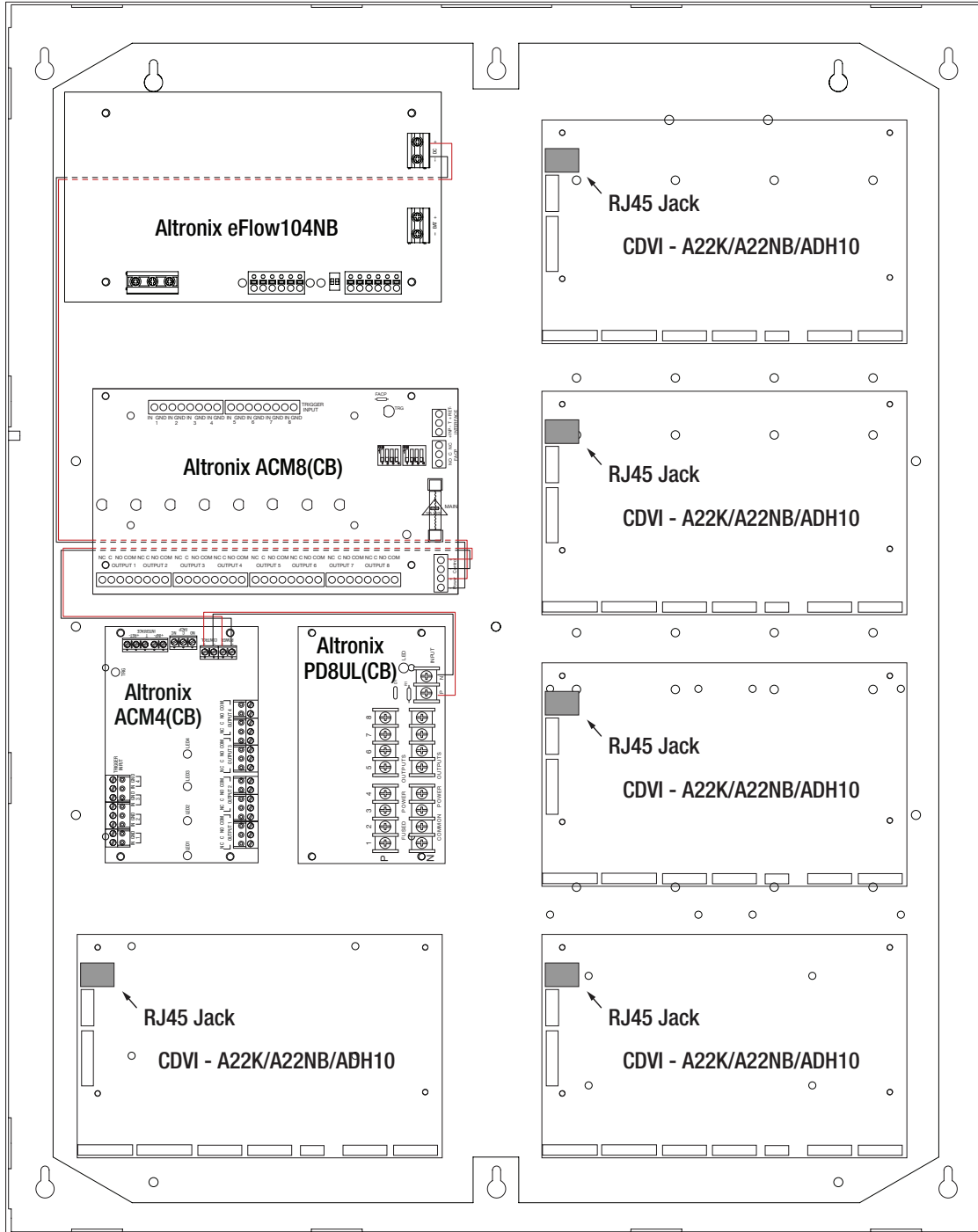

Fig. 3a

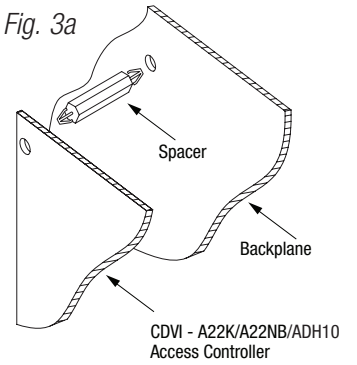
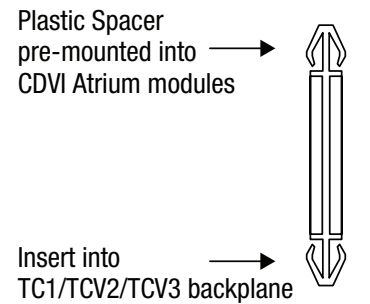

Fig. 3b



## T2CVK33F10 and T2CVK33F10Q: Configuration of CDVI A22K/A22NB/ADH10 Boards

1. Fasten spacers (supplied with A22K/A22NB/ADH10) to CDVI A22K/A22NB/ADH10 board (Fig. 4b, pg. 5).
2. Mount CDVI A22K/A22NB/ADH10 boards into the correct positions (Fig. 4, pg. 5) by positioning spacers over appropriate holes on the backplane and depressing down on board to secure spacer to the backplane (Fig. 4a, 4b, pg. 5).

**Note:** CDVI A22K/A22NB/ADH10 boards have one (1) RJ45 jack each.

Please make sure that they are mounted correctly, as shown in Fig. 4 below.

3. Fasten backplane to Trove2 enclosure utilizing pan head screws (provided).

Fig. 4

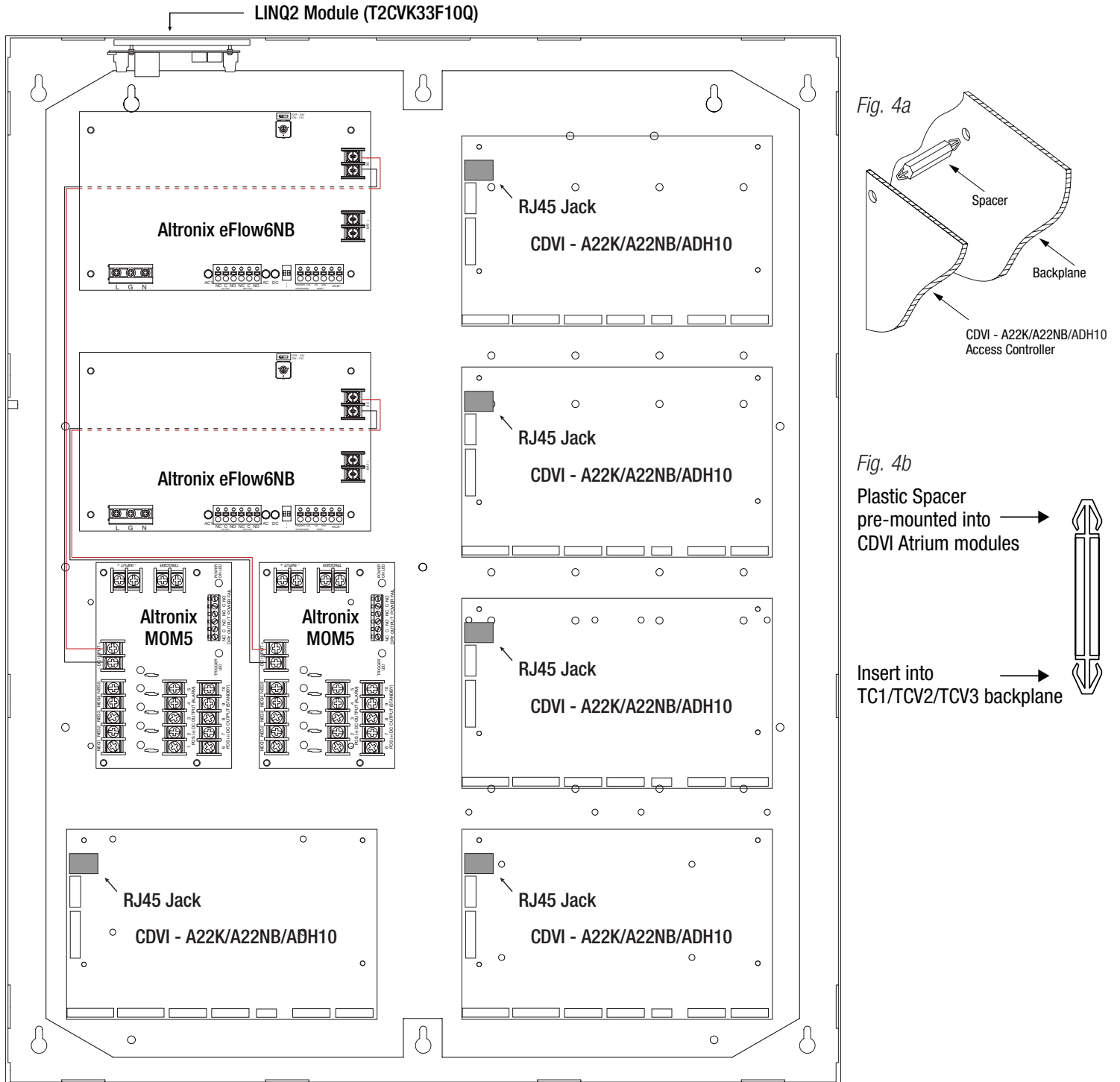

Fig. 4a

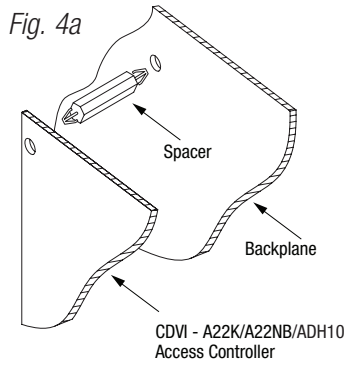
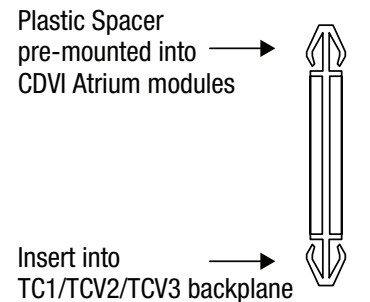

Fig. 4b



## T3CVK77F20(D): Configuration of CDVI A22K/A22NB/ADH10 Boards

1. Fasten spacers (supplied with A22K/A22NB/ADH10) to CDVI A22K/A22NB/ADH10 board (Fig. 5b, pg. 6).
2. Mount CDVI A22K/A22NB/ADH10 boards into the correct positions (Fig. 5, pg. 6) by positioning spacers over appropriate holes on the backplane and depressing down on board to secure spacer to the backplane (Fig. 5a, 5b, pg. 6).

**Note:** CDVI A22K/A22NB/ADH10 boards have one (1) RJ45 jack each.

Please make sure that they are mounted correctly, as shown in Fig. 5 below.

3. Fasten backplane to Trove3 enclosure utilizing pan head screws (provided).

Fig. 5

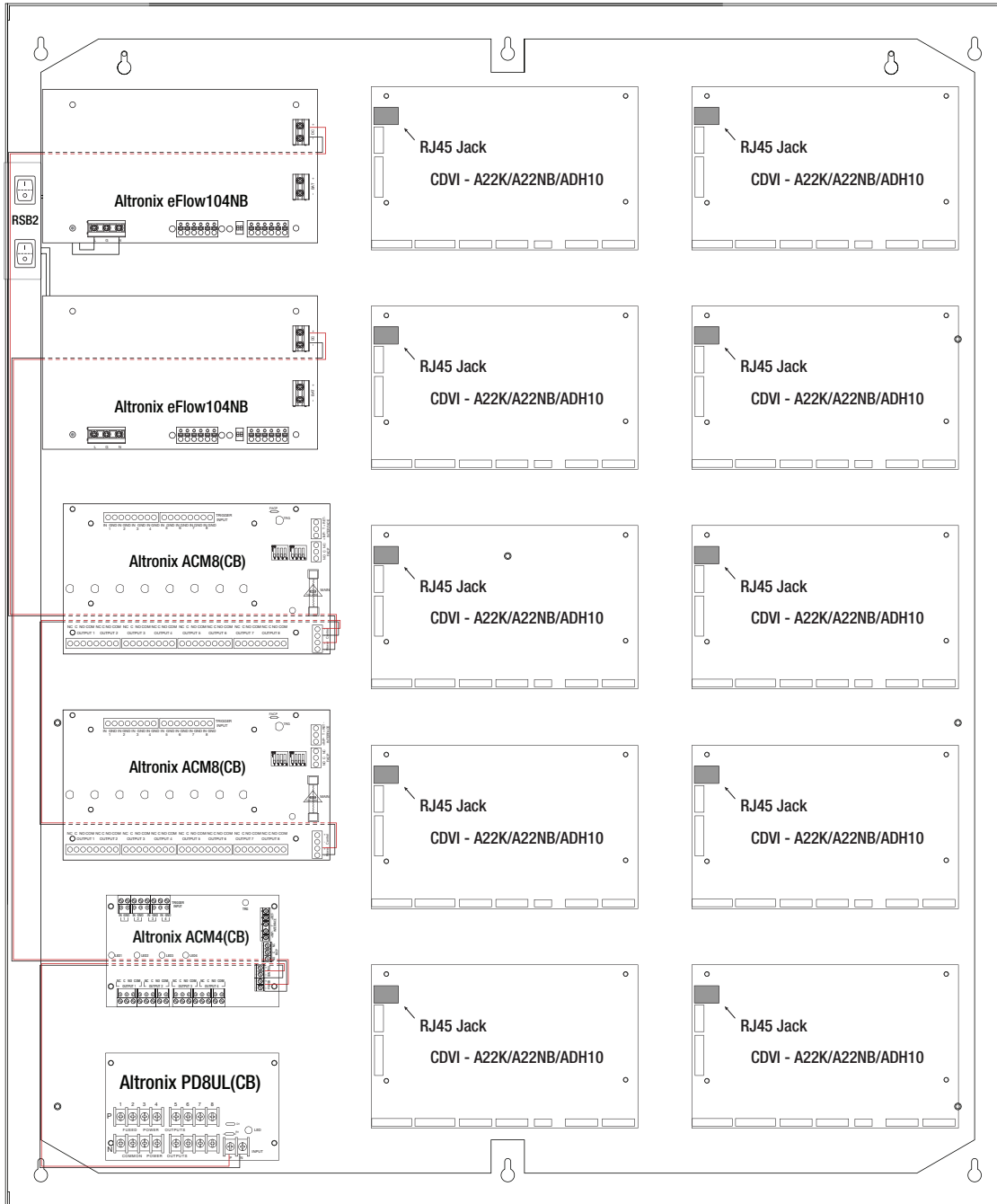

Fig. 5a

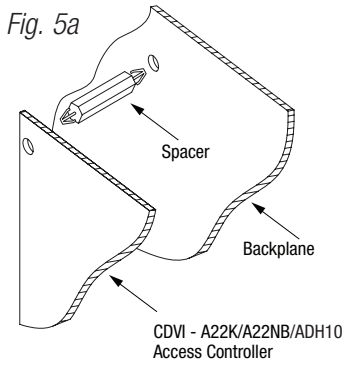
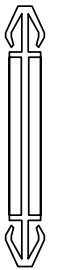

Fig. 5b

Plastic Spacer  
pre-mounted into  
CDVI Atrium modules

Insert into  
TC1/TCV2/TCV3 backplane





## eFlow Power Supply/Chargers can be Controlled and Monitored while Reporting Power/Diagnostics from Anywhere over the Network...

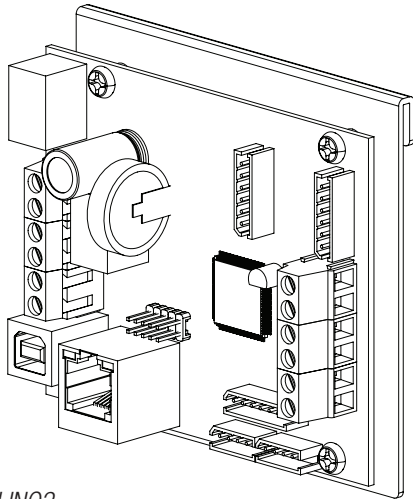

# LINQ™

### LINQ2 - Network Communication Module

LINQ2 provides remote IP access to real-time data from eFlow power supply/chargers to help keep systems up and running at optimal levels. It facilitates fast and easy installation and set-up, minimizes system downtime, and eliminates unnecessary service calls, which helps reduce Total Cost of Ownership (TCO) - as well as creating a new source of Recurring Monthly Revenue (RMR).

LINQ2

### Features:

- UL Listed in the U.S. and Canada.
- Local or remote control of up to (2) two Altronix eFlow power output(s) via LAN and/or WAN.
- Monitor real time diagnostics: DC output voltage, output current, AC & battery status/service, input trigger state change, output state change and unit temperature.
- Access control and user management: Restrict read/write, Restrict users to specific resources
- Two (2) integral network controlled Form "C" Relays.
- Three (3) programmable input triggers: Control relays and power supplies via external hardware sources.
- Email and Windows Dashboard notifications
- Event log tracks history.
- Secure Socket Layer (SSL).
- Programmable via USB or web browser - includes operating software and 6 ft. USB cable.

### LINQ2 Mounts Inside any Trove Enclosure

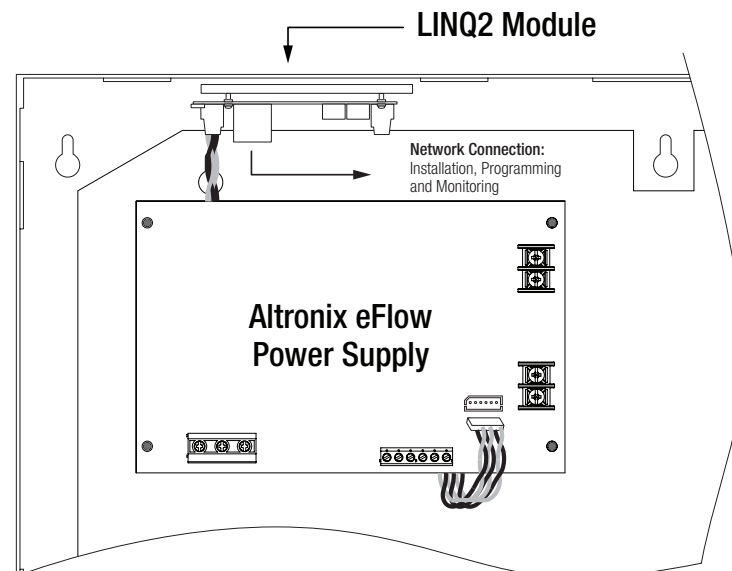

## Notes:



## Notes:

# T1CVK3F4(D) (Trove1) Enclosure Dimensions (H x W x D approximate):

18" x 14.5" x 4.625" (457mm x 368mm x 118mm)

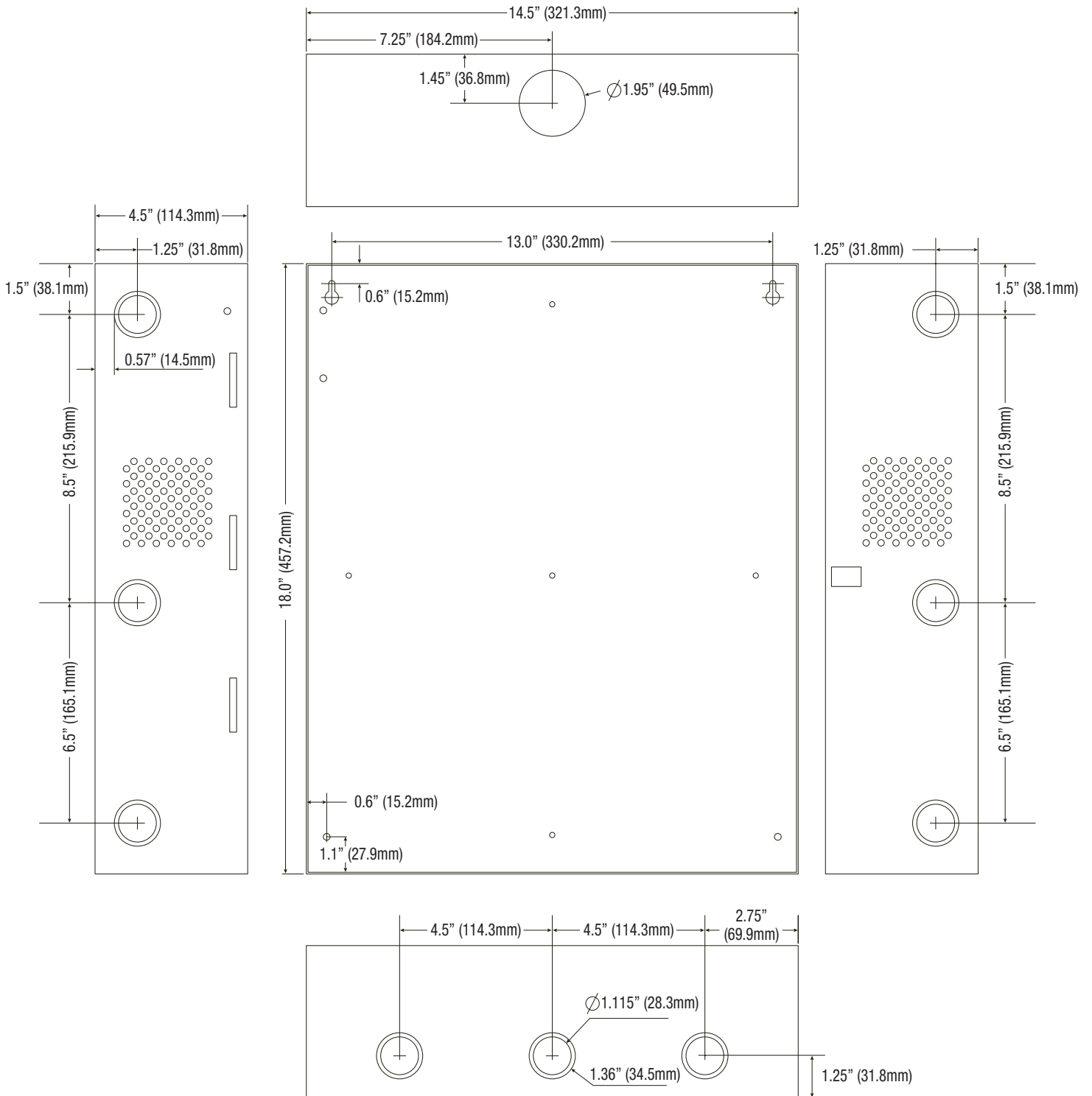

**T2CVK7F10(D) and T2CVK33F10(Q) (Trove2) Enclosure Dimensions** (H x W x D approximate):  
 27.25" x 21.5" x 6.5" (692.2mm x 552.5mm x 165.1mm)

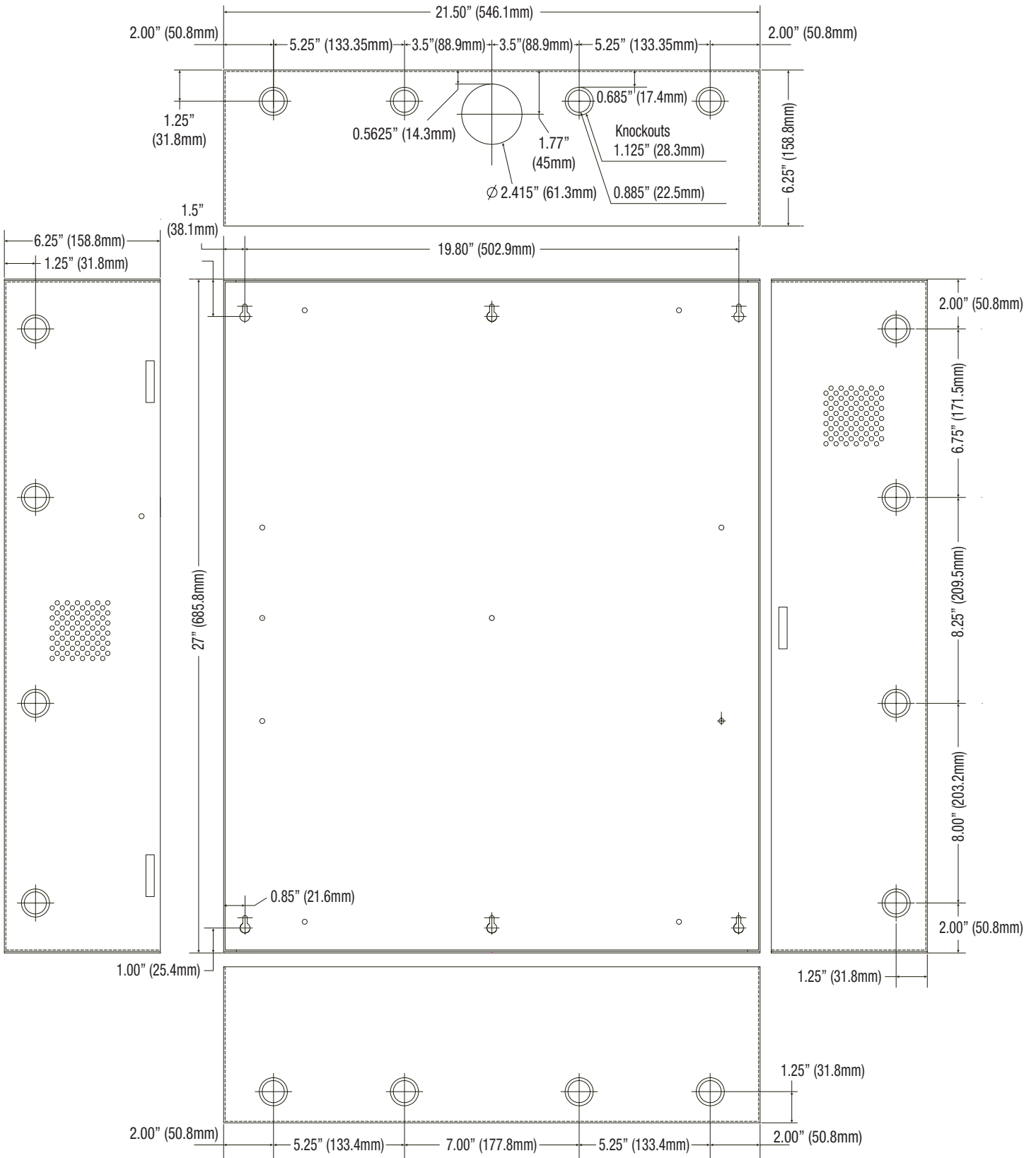

# T3CVK77F20(D) (Trove3) Enclosure Dimensions (H x W x D approximate): 36.12" x 30.125" x 7.06" (917.5mm x 768.1mm x 179.3mm)

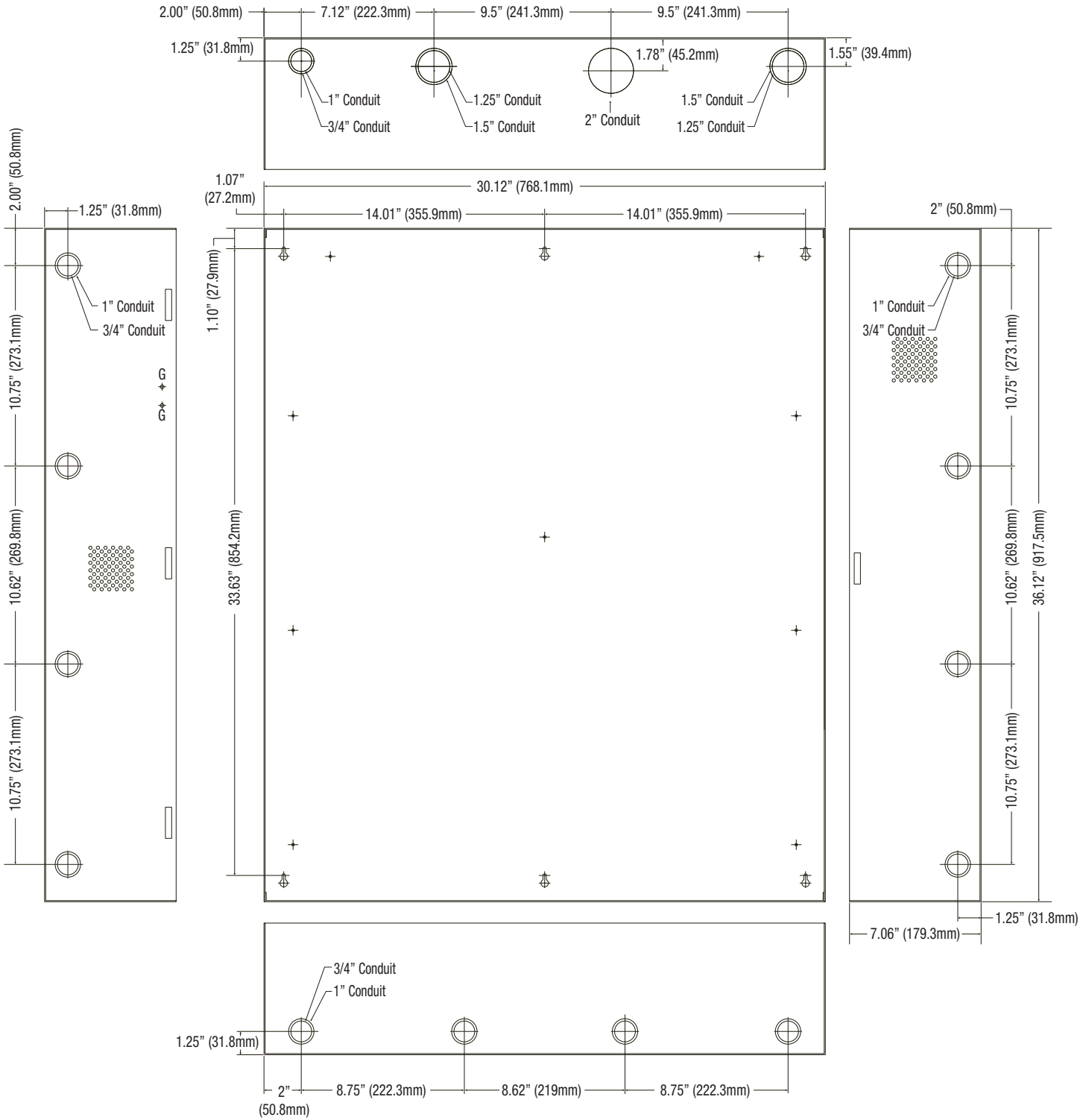

Altronix is not responsible for any typographical errors. Product specifications are subject to change without notice.

140 58th Street, Brooklyn, New York 11220 USA | phone: 718-567-8181 | fax: 718-567-9056  
 website: www.altronix.com | e-mail: info@altronix.com | Lifetime Warranty  
 IITrove CDVI Kits

K27W

